

Carrier Ethernet Services - The Future

Public Multi-Vendor Interoperability Test

Berlin, September 2008



EDITOR'S NOTE



Carsten Rossenhoefel
Managing Director

This year the interoperability hot staging test for the Carrier Ethernet World Congress took place in parallel to the Beijing Olympics.

80 engineers from 28 participating vendors with over 100 systems attended our test. According to data from Heavy Reading, more than

90% of the Carrier Ethernet switch and router market share were represented in this test.

The participating vendors verified 34 test areas in any-to-any combinations in ten days, truly challenging the Olympic motto "Faster, Higher, Stronger". Carrier Ethernet implementations support more functions and cover more markets today — ranging from core to microwave to access, E-Lines to E-Trees, triple play to mobile backhaul.

It was an outstanding experience to witness the massive testing feast, a unique get-together of virtually all leading players with one single goal: To improve multi-vendor interoperability of advanced Carrier Ethernet implementations.

An EANTC panel of service providers worldwide including experts from COLT, GVT Brazil, PT TELKOM Indonesia, T-Systems and Metanoia Inc reviewed the test plan thoroughly to ensure the event's scenarios are realistic and sound.

Interestingly, market forces are operating at full strength. This year, we once again tested three transport technologies in the test event's metro/aggregation networks: MPLS, PBB-TE and T-MPLS. These three compete to some extent — at our test, they all proved being well suited for the transport of Carrier Ethernet services.

Service OAM support is becoming mandatory for aggregation and CPE devices; the Ethernet microwave market flourishes; mobile backhaul pushes support for backwards compatibility (ATM pseudowires, circuit emulation) and new features (clock synchronization, IEEE 1588v2, E-Tree, among others).

This white paper summarizes in detail the monumental effort that the participating vendors and EANTC team underwent. Enjoy the read.

INTRODUCTION

This year's interoperability event focused on the *Future of Carrier Ethernet Services*. While each previous event concentrated on specific topics such as mobile backhaul or service creation, this event aimed to congregate the knowledge and experience the industry gained in the last four years into a single modern, converged network showing all that a tier-one service provider is likely to encounter. We therefore tested:

- Converged residential, business and Mobile Backhaul services
- Clock synchronization
- Business services realized using E-Line, E-LAN and for the first time E-Tree services
- The leading access, transport and aggregation technologies
- Microwave access and transport
- Ethernet OAM: Fault management and performance monitoring
- High availability
- Management and SLA reporting

In order to construct such a large test network and cover all the above test areas a ten day, closed doors hot staging event was conducted at EANTC's lab in Berlin, Germany.

Since the first Carrier Ethernet World Congress in 2005, EANTC has organized interoperability test events which are then showcases at the congress.

Our interoperability showcases are driven by three main goals:

Technical – Through participation in the event, vendors have the opportunity to verify the interoperability of their devices and protocol implementations against the majority of the industry's leading vendors.

Marketing – The participants can showcase the interoperability of their latest solutions on a unique, large-scale platform.

Standards – When fundamental issues are found during the hot staging event EANTC reports the discoveries to the standard bodies. These in turn update the standards.

EANTC started the preparation for the event by inviting interested vendors to weekly conference calls during which the technical and marketing goals for the event were discussed and agreed. The test plan, created by EANTC based on the test topics suggested by the vendors, expanded on the experience gained from previous events and was lined up with recent IEEE, IETF, ITU-T and MEF standards.

TABLE OF CONTENTS

Participants and Devices	3
Network Design	4
Interoperability Test Results	4
Ethernet Service Types	4
Diverse Access Technologies	6
Diverse Transport	7
MPLS Core	8
E-NNI	9
Mobile Backhaul	10
Clock Synchronization	14
Ethernet OAM	15
Resilience and Fault Detection	18
Management and SLA Reporting	21
Acronyms	22
References	23

PARTICIPANTS AND DEVICES

Vendor	Participating Devices
Actelis Networks	ML658
ADVA Optical Networking	FSP 150CC-825
Alcatel-Lucent	1850 TSS-40 5650 CPAM 7450 ESS-6 7705 SAR 7750 SR7 9500 MPR
Calnex Solutions	Paragon Sync
Cambridge Broadband Networks	VectaStar
Ceragon Networks	FibeAir IP-MAX ² FibeAir IP-10
Ciena	LE-311v LE-3300
Cisco Systems	7606 7604 ME4500 Catalyst 3750-ME ME-3400-2CS ME-3400-12CS
ECI Telecom	SR9705
Ericsson	Marconi OMS 2400
Foundry Networks	NetIron XMR 8000
Harris Stratex Networks	Eclipse (Gigabit) Radio
Huawei Technologies	NE5000E Cluster System NE40E-4 CX600-4
InfoVista	VistaInsight for Networks
Ixia	XM2 IxNetwork
Juniper Networks	M10i MX240 MX480
NEC Corporation	CX2600 PASOLINK NEO PASOLINK NEO TE
Nokia Siemens Networks	hiD 6650 Flexi WCDMA BTS FlexiHybrid RACEL

Vendor	Participating Devices
Nortel	Metro Ethernet Routing Switch (MERS) 8600
RAD Data Communications	ACE-3205 ACE-3200 ACE-3400 ASMi-54 Egate-100 ETX-202A ETX-202A/MiRiCi ETX-202A/MiTOP IPMUX-216/24 LA-210 OP-1551 RiCi-16 RiCi-155GE
Redback Networks — an Ericsson Company	SmartEdge 400
Rohde & Schwarz SIT	SITLine ETH
SIAE MICROELETTRONICA	ALS ALFO
Spirent Communications	Spirent TestCenter
Symmetricom	TimeProvider 5000 PTP Grand Master TimeCesium 4000
Tejas Networks	TJ2030
Telco Systems — a BATM Company	T5C-XG T5C-24F T5C-24G T-Marc-250 T-Marc-254 T-Marc-340 T-Marc-380 T-Metro-200
Tellabs	8830 Multiservice Router

Service Provider Test Plan Review

The draft test plan was reviewed by a panel of global service providers in July this year. Their feedback and comments were reflected in the final version of the test plan. EANTC and the participating vendors would like to thank: COLT, GVT Brazil, PT TELKOM Indonesia, T-Systems and Metanoia Inc.

NETWORK DESIGN

As in previous events we set off to construct a network that would allow all participating vendors to establish end-to-end Ethernet services with any of the other vendors. One of the central design considerations for the network was to enable any device positioned in the access network to reach any other access network device regardless of the other device's point of attachment to the network. This proved to be especially useful for such end-to-end tests as Service OAM or Mobile Backhaul. The specifics of these tests can be found in the test case sections.

We also aimed to build a network that would look familiar to service providers. It is perhaps unrealistic to expect that service providers will incorporate all current transport technologies into their network. Nevertheless the familiar network domains are likely to exist: access, aggregation, metro and core, regardless of the chosen transport technology. It is realistic, however, to expect service providers to use MPLS in the core.

Looking at the network from a customer's perspective, we used the following network areas:

- **Access:** The devices that normally exist at the customer premise or by NodeBs or base stations were positioned here. We were lucky to see a diverse number of access technologies for transporting Ethernet such as microwave links, copper, and fiber. These devices implemented the UNI-C construct as defined by the MEF.
- **Aggregation:** The aggregation area of a network consisted of a variety of solutions meant to aggregate customer premise devices. This included Provider Bridges and H-VPLS Multi-Tenant Unit Switches (MTU-s). When applicable these devices performed the UNI-N role in the network.
- **Metro:** Three different transport technologies were used in each of the three metro area networks: MPLS, PBB-TE and T-MPLS. This allowed each transport technology to test its own resiliency and Network-to-Network Interface (NNI) solutions.
- **Core:** As stated above, IP/MPLS was used to support connectivity between the different metro area networks in order to realize end-to-end services. In addition, MPLS Layer 3 VPNs as defined in RFC 4364 were tested in the core of the network.

The physical network topology presented here depicts the roles of all the devices and their respective placement in the network. Please note that many tests required logical connectivity between the devices, often at an end-to-end nature, which will be shown, where applicable, using logical topologies in each test section.

INTEROPERABILITY TEST RESULTS

In the next sections of the white paper we describe the test areas and results of the interoperability event. The document generally follows the structure of the test plan.

Please note that we use the term »tested« when reporting on multi-vendor interoperability tests. The term »demonstrated« refers to scenarios where a service or protocol was terminated by equipment from a single vendor on both ends.

ETHERNET SERVICE TYPES

The Metro Ethernet Forum (MEF) has defined three Ethernet service types in order to allow the industry and specifically the customers interested in the services to have a common language to discuss such Ethernet based services. The three service types are defined in terms of the Ethernet Virtual Connection (EVC) construct:

- E-Line – Point-to-point EVC
- E-LAN – Multipoint-to-multipoint EVC
- E-Tree – Rooted-multipoint EVC

While the E-Line service type provides a service to exactly two customer sites, the E-LAN and E-Tree service types allow the connection of more than two customer sites. In contrast to the E-LAN service type which allows an any-to-any connectivity between customer sites, E-Tree introduces two different roles for customer sites: leaf and root. An E-Tree service facilitates communication between leaves and roots, however, leaves can not communicate with each other directly. An E-Tree service implemented by a rooted-multipoint EVC can be used to provide multicast traffic distribution and hub-and-spoke topologies (e.g. DSL customers to BRAS).

In the test network we instantiated three specific definitions of service types: Ethernet Virtual Private Line (EVPL), Ethernet Virtual Private LAN (EVP-LAN), and Ethernet Virtual Private Tree (EVP-Tree). All services were configured manually in the network. Due to the increasingly large amount of devices and vendors we had present at the hot staging, this process was time consuming and prone to mistakes. A multi-vendor provisioning tool would have been ideal for the testing and is recommended for any service provider planning to deploy Carrier Ethernet services.

The services created in the network were configured in two ways:

- EVCs that remained within the same metro area network
- EVCs that crossed the network core

The sections below describe the services in the network in detail.

E-Tree

For the first time at an EANTC interoperability event, an E-Tree service instantiation was established. One EVP-Tree was configured with one root node within the MPLS metro area and leaves throughout all network areas. The MEF defines an E-Tree service to be a rooted Ethernet service where the roots are able to communicate with all leaves, and all leaves are able to communicate with the roots, but not with each other.

This service utilized each metro technology in a unique way. The MPLS metro used a separate VPLS instance to create this service, using different split horizon groups to ensure that leaf UNIs could only communicate with the root UNI, but could not establish communication between each other. The Cisco ME4500 implemented the root UNI-N and handed the service off to the Nokia Siemens Networks hiD 6650 which propagated the tree into the MPLS metro. The Juniper MX480 configured a leaf using MPLS towards the Cisco 7606 which treated this connection as the root for the core network. Three leaves were configured within the

core, two of which provided E-NNI leaf connectivity to the other metros - the Alcatel-Lucent 7750 SR7 to T-MPLS and the ECI SR9705 to PBB-TE. The Tejas TJ2030 interpreted this E-NNI connection as the root connectivity for the PBB-TE metro, and the Ericsson Marconi OMS 2400 did the same for the T-MPLS metro.

The diagram in figure 1 shows all points where E-Tree traffic was verified. The logical connections represent something different in each area: Ethernet pseudowires in the MPLS, PBB-TE trunks in the PBB-TE, and TMCs in the T-MPLS networks.

E-LAN

One EVP-LAN was configured in the network with customer ports in all three metro areas. The construction of the EVP-LAN service used different mechanisms in each metro area. These mechanisms are described in details in the diverse transport section.

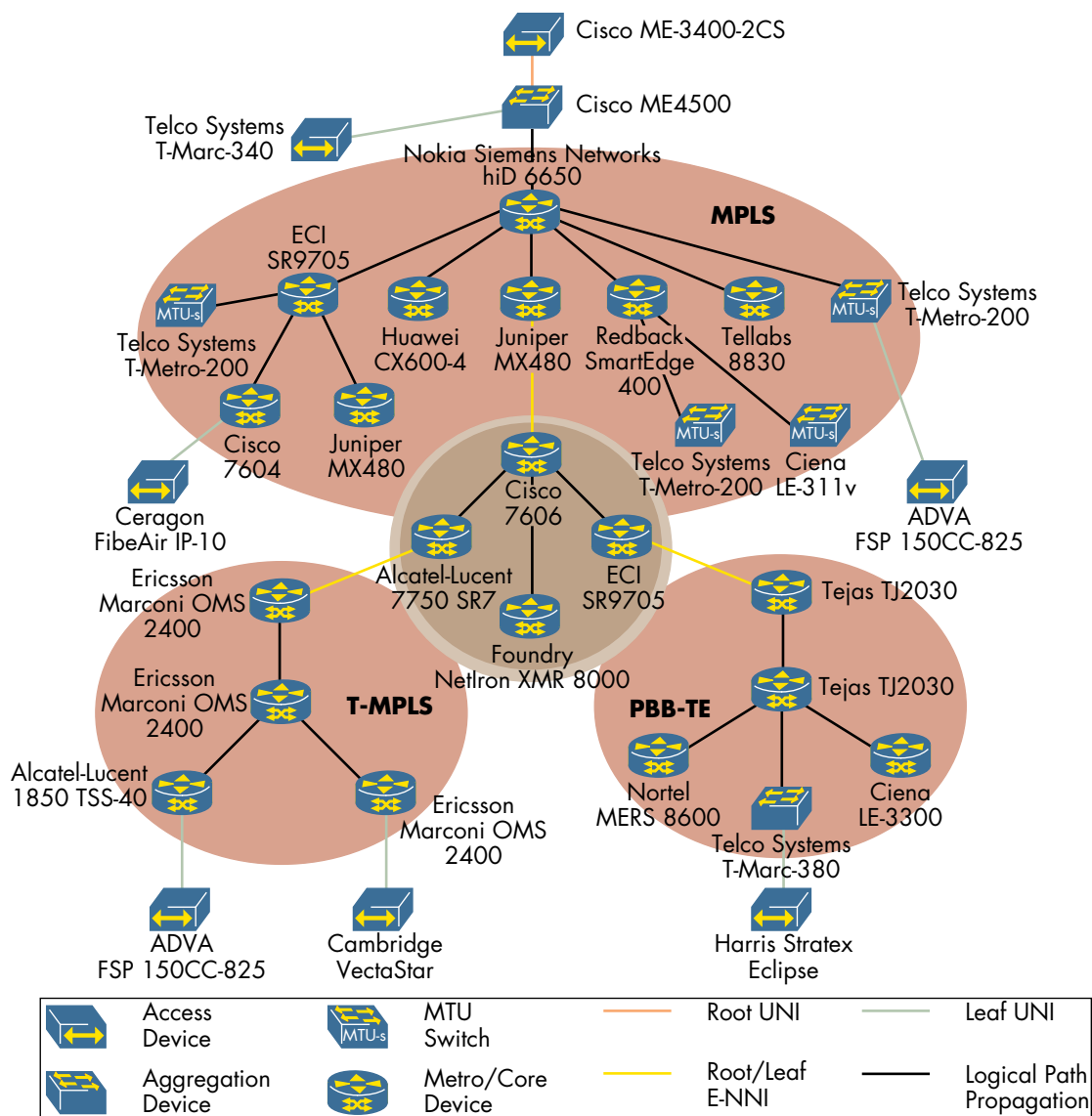

Figure 1: E-Tree logical connections

E-Line

The E-Line service type configured in the network used Virtual LAN (VLAN) IDs to distinguish between the various services. In some cases, much like real world networks, a switch positioned at the customer site would add a Service VLAN tag (S-VLAN) to the Ethernet traffic provided by the customer, therefore, allowing the customer to maintain its private VLAN addressing scheme and separate the customer VLAN space from the provider's.

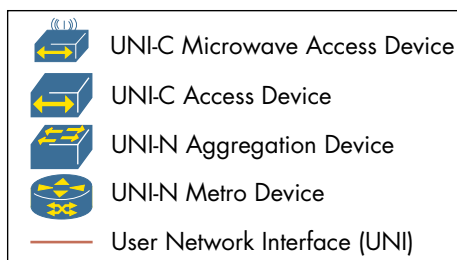
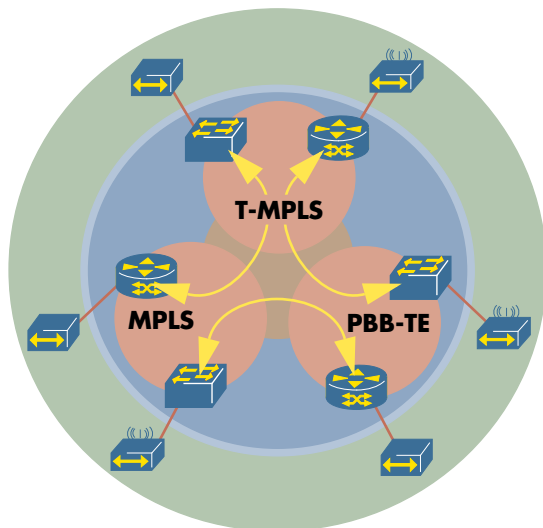

Figure 2: E-Line service creation

All vendor devices successfully participated in creation of E-Line services. From the number of combinations tested, we are confident that an any-to-any combination of endpoints is possible.

Three of the E-Line services created between the three metro clouds were encrypted using Rohde & Schwarz SITLine ETH. The encryption device was situated between the UNI-C (which was emulated by Spirent TestCenter) and Alcatel-Lucent 7705 SAR, Telco Systems T-Marc-380 and Telco Systems T-Metro-200 all of which were serving as UNI-N devices. Once the encryption connections were established we verified that the EVCs were indeed encrypted and that the connection remained stable.

DIVERSE ACCESS TECHNOLOGIES

The different services in the test network used a variety of access technologies to reach the simulated last mile customer access device. Most services used fiber (multi-mode) and copper based Gigabit Ethernet. One UNI was implemented over a single strand fiber cable using IEEE 802.3ah defined 1000BASE-BX10 between the Cisco ME4500 and the Cisco ME-3400-2CS. Two Actelis ML658 devices used G.SHDSL.bis to connect the aggregation area to the access. RAD demonstrated a wide variety of access technologies including EFM bonding of four G.SHDSL.bis pairs between the ASMi-54 and LA-210. In addition, RAD demonstrated Ethernet over PDH connectivity with the ETX-202A with MiRiCi E1/T1 over a single E1 link and the RiCi-16 over 16 bonded E1 links, both aggregated by the Egate-100. The PDH to channelized STM-1 was performed by the OP-1551. Several Ethernet access links comprised of two Ethernet links with a microwave signal in between. These systems are described in more detail below.

Microwave for Access and Transport

In recent years we have seen an increased interest in our interoperability events from vendors offering microwave connectivity and network solutions. Microwave solutions alleviate the need to roll out physical wire infrastructure and are especially prevalent in such areas as cellular backhaul, emerging markets, large corporation networks, hospitals, and mobile-fixed operators.

This event enjoyed the participation of the following microwave products: Alcatel-Lucent 9500 MPR, Cambridge VectaStar, Ceragon FibeAir IP-10 and FibeAir IP-MAX², Harris Stratex Eclipse, NEC PASOLINK NEO, Nokia Siemens Networks Flexi-Hybrid, and SIAE MICROELETTRONICA ALS and ALFO. In addition, Cambridge Broadband Networks provided a point-to-multipoint microwave system with which providers can connect either multiple customer offices or multiple base stations via Ethernet or E1 lines.

Since the radios rely on a signal through the air some weather events such as rain and heavy fog can cause the signal to degrade effectively decreasing the range or capacity of the link. Radio devices can recognize the decrease in air-link capacity and some solutions can distinguish which frames should be prioritized and further transported versus which frames will be dropped. The Alcatel-Lucent 9500 MPR, Cambridge VectaStar, Ceragon FibeAir IP-10, Harris Statex Eclipse, and SIAE MICROELETTRONICA ALFO showed this functionality by decreasing the modulation scheme in Quadrature Amplitude Modulation (QAM) which caused traffic loss only to best effort frames and no or minimal loss to prioritized traffic with unaffected latency.

Services relying on microwave equipment will need to be made aware when the microwave signal is too weak to transmit traffic. The link state propagation function disables the Ethernet link state for all ports associated with the microwave link. This functionality was demonstrated by the Ceragon FibeAir IP-10, Harris Stratex Eclipse and the SIAE MICROELETTRONICA ALFO. These devices also showed their capability to propagate an incoming loss of signal on a tributary Ethernet port across the microwave link and switching off the appropriate physical port on the other side of the radio connection.

Cambridge Broadband Networks demonstrated their ability to share point-to-multipoint link capacity between several end stations. In the demonstration three end stations were defined to share a 45 Mbps wireless link to a central controller. Cambridge Broadband Networks showed that when capacity between one base station and controller was not used, the remaining base stations could use the extra capacity.

Over the last few years we have seen an impressive increase in the features built into microwave transport. While historically microwave solutions were used to provide a virtual wire, we see more and more intelligence built into the solutions — on several products a complete Ethernet switch functionality.

DIVERSE TRANSPORT

The Carrier Ethernet architecture specified by the MEF is agnostic to the underlying technology used to provide Carrier Ethernet services. The creation and support of such services is, however, an essential component of the interoperability test event. Mainly three technologies compete for Carrier Ethernet Transport: MPLS, PBB-TE and T-MPLS. During this event we had the opportunity to verify all three technologies. The following sections describe test results for each technology in detail.

MPLS

MPLS is defined in a set of protocols standardized by the Internet Engineering Task Force (IETF) and the IP/MPLS Forum. MPLS is positioned to deliver layer 2 and layer 3 services including Ethernet services as defined by the MEF while being agnostic to the underlying transport technology.

The tests in this area were based on previous experience gained from EANTC's Carrier Ethernet World Congress and MPLS World Congress interoperability test events and reached a larger number of participants than in previous events, including a total of 12 vendors testing MPLS implementations. The MPLS metro domain operated independently from the MPLS core network.

The MPLS metro network was built solely for the purpose of Carrier Ethernet services. Multipoint-to-multipoint services were facilitated with the creation

of a single Virtual Private LAN Services (VPLS) instance utilizing both VPLS PEs and H-VPLS MTU switches established between the following devices: Alcatel-Lucent 7450 ESS-6, Ciena LE-311v, Cisco 7604 and Catalyst 3750-ME, ECI SR9705, Huawei CX600-4, Ixia XM2 IxNetwork, Juniper MX240 and MX480, Nokia Siemens Networks hiD 6650, Redback SmartEdge 400, Tellabs 8830, and Telco Systems T-Metro-200. This VPLS instance used LDP for signaling statically configured peers as described in RFC 4762. These devices also established Ethernet pseudowires using LDP to facilitate point-to-point Ethernet services.

A separate VPLS instance was used to test BGP-based Auto-Discovery, which was successfully established between the Cisco 7606 and the ECI SR9705. A total of four vendors were interested in testing BGP-based Auto-Discovery, one of which uncovered an interoperability issue during the tests where packets captures were taken to be further studied in their labs.

In order to test the interoperability of VPLS implementations which use BGP for signaling as described in RFC 4761, another separate VPLS instance was configured. This was tested between the following devices with BGP-based Auto-Discovery enabled: Huawei CX600-4 and Huawei NE40E-4, and Juniper MX240 and Juniper MX480. The Juniper MX480 performed an interworking function between this BGP signaled VPLS domain and an LDP signaled VPLS domain with the Cisco 7604.

Provider Backbone Bridge Traffic Engineering (PBB-TE)

One of the potential solutions to delivering MEF defined services using Ethernet technologies only is the IEEE defined Provider Backbone Bridge Traffic Engineering (PBB-TE). The technical specification is defined in 802.1Qay which is working its way through the standard process and is in draft version 3.0 at the time of the testing. The standard extends the functionality of the Provider Backbone Bridges (802.1ah) adding a connection-oriented forwarding mode by creating point-to-point trunks. These trunks deliver resiliency mechanisms and a configurable level of performance.

The vendors participating in the PBB-TE transport domain included Ciena LE-311v2, Ciena LE-3300, Ixia XM2 IxNetwork, Nortel MERS 8600, and Tejas TJ2030.

In the PBB-TE Metro network we were able to test the establishment of E-Line, E-LAN, and E-Tree services. The establishment of E-Line services was straightforward as we tested it in several previous events. E-LAN and E-Tree services creation was tested for the first time within the PBB-TE cloud. For the E-LAN service Ciena LE-3300 and Tejas TJ2030 switches established bridging instances per PBB-TE trunk and C-VLAN/S-VLAN IDs. Every PBB-TE edge device established a trunk for each particular UNI to one of the bridges. A few issues related to usage of different Ethertype values in CFM messages,

padding, and different interpretation of CCM intervals were discovered in the initial configuration phase of PBB-TE trunks, however, these issues were resolved quickly.

In addition, the Nortel MERS 8600 and the Spirent TestCenter tested one of the latest additions to Ethernet - Provider Link State Bridging (PLSB) – a pre-standard implementation of the IEEE 802.1aq (Shortest Path Bridging) which is in draft version 0.3. The protocol uses the IETF defined IS-IS protocol for distributing Backbone MAC addresses and Service IDs of participating nodes across the network. Once the network topology has been learned, IS-IS is used to establish loop-free multipoint-to-multipoint services. The forwarding plane uses PBB (802.1ah), however since the other devices in the PBB-TE network did not support PLSB the three Nortel MERS 8600 devices were able to use a re-encapsulation of either PBB-TE trunks or VLAN tags to peer within the PBB-TE network. The Nortel MERS 8600 devices and the Spirent TestCenter emulated nodes successfully learned the appropriate B-MAC addresses, and forwarded the respective traffic accordingly.

Tejas Networks demonstrated a logical Ethernet LAN network with an IEEE 802.1ad based Ethernet Ring Protection Switching (ERPS). This ring based control protocol being standardized under ITU-T G.8032 is a protection mechanism which offers carriers a deterministic sub-50 ms network convergence on a fiber failure as opposed to the conventional loop-breaking mechanisms like Rapid Spanning Tree Protocol (RSTP). ERPS convergence time is independent to the number of nodes in the network, thereby vastly enhancing the scalability of a carrier network. We measured failover and restoration of below 35 ms for the demonstrated ERPS.

Transport MPLS (T-MPLS)

This test marked the third T-MPLS interoperability testing at EANTC. The following devices successfully participated in the T-MPLS area during the event: Alcatel-Lucent TSS-40, Ericsson Marconi OMS 2400, and Ixia XM2 IxNetwork.

The T-MPLS standards specify the networking layer for packet transport networks based on MPLS data plane and designed for providing SONET/SDH-like OAM and resiliency for packet transport networks.

Alcatel-Lucent and Ericsson successfully tested the creation of E-Line, E-LAN and E-Tree services, the last of which was a first at an EANTC interoperability event. Both participants constructed T-MPLS paths (TMP) which are end-to-end tunnels that aggregate T-MPLS channels (TMC) representing the services. The TMPs and TMCs were transported over different physical layer types including 1 Gbit Ethernet, 10 Gbit Ethernet, ITU-T G.709, and SDH STM-16. The Alcatel-Lucent 7705 SAR was used as a non-T-MPLS switch in the aggregation area, interfacing to the T-MPLS domain by means of statically configured MPLS labels.

The E-LAN and E-Tree services were configured

using a multipoint architecture similar to VPLS. On one particular E-Line service, both Alcatel-Lucent 1850 TSS-40 and Ericsson Marconi OMS 2400 were able to successfully test Quality of Service (QoS) by distinguishing between three different classes of service within the same Ethernet service and only drop low priority traffic when interfaces were oversubscribed.

Since the T-MPLS standards do not define a control plane protocol, the T-MPLS connections between vendors were manually configured. Ericsson used two proprietary management tools (ENEA and DiToNe) to setup the T-MPLS network configuration on their devices.

T-MPLS to MPLS-TP Migration

Following the approval of the first version of the ITU recommendations on T-MPLS, the IETF and ITU-T jointly agreed to work together to extend MPLS protocols to meet transport network requirements in order to ensure a smooth convergence of MPLS-based packet transport technology. A Joint Working Group (JWT) was formed between the IETF and the ITU to achieve mutual alignment of requirements and protocols and to analyse the different options for T-MPLS standard progress. On the basis of the JWT activity, it was agreed that the future standardization work will focus on defining a transport profile of MPLS (named MPLS-TP) within IETF and in parallel aligning the existing T-MPLS Recommendations within ITU-T to the MPLS-TP work in IETF.

At their Dublin meeting in July 2008, the IETF has initiated the work on MPLS-TP. Due to the fact that IETF MPLS-TP standard or drafts do not exist yet, we tested the implementations based on the T-MPLS ITU-T Recommendations currently in force and its relevant drafts.

It is our intention also to include the first implementations of MPLS-TP drafts at our next event.

MPLS CORE

Since MPLS is used by the majority of service providers as core technology it is only logical that when providers add Carrier Ethernet services to their product offering the MPLS core will be used. We followed this approach and used the MPLS core to connect between three different Ethernet transport metro areas. The core area was constructed using the following edge devices, all of which successfully established multiple VPLS domains and CVirtual Private Wire Services (VPWS) using LDP for various Ethernet services: Alcatel-Lucent 7750 SR7, Cisco 7606, ECI SR9705, Foundry NetTron XMR 8000, Huawei NE40E-4, Juniper M10i, and Tellabs 8830. All devices were physically connected to Huawei NE5000E cluster system P router (P for Provider, as opposed to PE for Provider Edge) through which all services were tunneled through by default.

In addition to providing transport for Ethernet services, all edge devices in the core established an IP/MPLS L3VPN service using BGP (based on RFC 4364). The Alcatel-Lucent 7750 SR7 and Cisco 7606 terminated Ethernet pseudowires into this VPN providing the potential to offer layer 3 services to customers which are not reachable otherwise.

EXTERNAL NETWORK TO NETWORK INTERFACE (E-NNI)

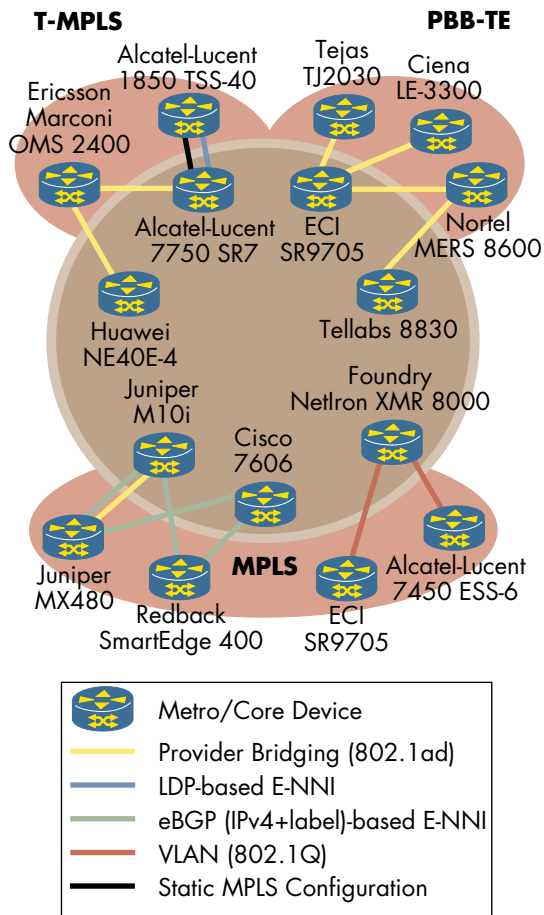

Figure 3: E-NNI to the core

As we described above three different technologies were used in the metro areas. The problem that every service provider then faces is to connect the metro area with the existing network core. In our test network, much like in most service provider networks, the core used MPLS for transport and services. Therefore, we required mechanisms to allow services originating on one metro area to cross the core and be received on other metro areas.

The following subsections describe the specific Network to Network Interface (E-NNI) solutions used in the network.

MPLS Metro Connectivity to the Core

Several options exist to allow connectivity between two MPLS areas. The preferred options were MPLS based, but one option used IEEE 802.1ad Provider Bridging tags, or simply 802.1Q VLAN tags to transport services between the two areas. The Label Edge Router (LER) in the MPLS core would strip the MPLS header from traffic before it forwarded the Ethernet frames to the LER in the MPLS metro. The S-Tag or VLAN tag would then signal to the MPLS metro device which pseudowire to forward the frames onto. Devices using VLAN tags were Alcatel-Lucent 7450 ESS-6, ECI SR9705, and Foundry NetIron XMR 8000.

The other option used to connect between administratively separated MPLS core and metros is referred to as pseudowire (PW) stitching. This involves the creation of two pseudowires, one in each domain, and then interconnecting them either within one device, or with a third pseudowire between the two edge devices. Vendors who took this approach chose the latter. In this case two MPLS labels must be signaled: the inner label (PW label) signaled by LDP, and the transport label (PSN label) signaled by either eBGP (IPv4+label) or LDP. To facilitate the transmission of LDP sessions, either a separate OSPF area was enabled between the two edge devices or a static route was used. Devices taking the PW stitching approach were Cisco 7606, Juniper M10i, Juniper MX480, and Redback SmartEdge 400.

PBB-TE Connectivity to the Core

As PBB-TE and 802.1ad are both part of the IEEE Provider Bridging domain of technologies, it is not surprising that Provider Bridging tags were supported across the board in the PBB-TE metro domain. All services crossing the core into the PBB-TE cloud used S-Tags (Service Tags) to distinguish each service between a core edge router and a PBB-TE switch. These devices included Ciena LE-3300, ECI SR9705, Nortel MERS 8600, Tejas TJ2030, and Tellabs 8830. One PBB-TE trunk was configured between Nortel MERS 8600 and Tejas TJ2030 and traversed the MPLS core.

T-MPLS Connectivity to the Core

Two options were used to establish services over an MPLS core into a T-MPLS network. The first was to use 802.1ad S-Tags, similarly to the MPLS metro.

The second option used was pseudowire stitching. The T-MPLS edge device terminated TMCs coming from the edges of the network and stitched them to an MPLS Ethernet pseudowire which was established with the neighboring core edge device. This was done using LDP for both MPLS labels, which ran over a separate OSPF area than the core. This option was tested between Alcatel-Lucent 1850 TSS-40 and the Alcatel-Lucent 7750 SR7, which also had some services configured over statically configured MPLS pseudowires.

MOBILE BACKHAUL

Traditionally, the interface between mobile base stations and base station controllers has been based on a number of parallel TDM circuits (for GSM, CDMA) or ATM connections (for the first versions of UMTS and CDMA 2000) carried on E1 or T1 links.

Several market studies show that the transport network costs account for 20–30% of a mobile operator's operational expenditure (OPEX).

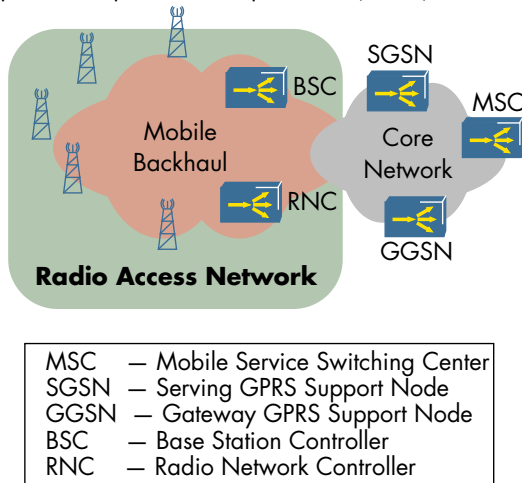

Figure 4: Mobile Backhaul scope

With the advent of high-speed data transport (HSPA) in 3G networks, with WiMAX and LTE on the horizon, the amount of data traffic in mobile networks has vastly grown and will continue to do so. Mobile operators are considering mobile backhaul over Carrier Ethernet networks, as these provide enough bandwidth for any predicted increase in data traffic and are more cost effective than the current TDM networks.

The main issue and test focus for Mobile Backhaul transport is the migration path from TDM/ATM to converged packet based services. Thousands of base stations will not be upgraded immediately or not at all. Migration paths vary widely depending on the specific service provider environment.

In this test event, we verified a number of migration scenarios, focusing TDM and ATM transport over Carrier Ethernet as well as clock synchronization.

The following table provides an overview of the transport requirements imposed by different mobile network technologies.

Mobile Network Service Types	Carrier Ethernet Network Requirements						
	TDM Circuit Emulation	ATM Pseudowires	E-Lines Services	E-LAN Services	E-Tree Services	Sub-50-ms Resiliency	Sub-second Resiliency
Traditional GSM	X					X	
Traditional 3G (UMTS Rel. 99 / CDMA2000)		X				X	
Hybrid 3G offload (ATM-based voice; IP tunneled data)		X	X				X
Full packet-based 3G			a		X	X	
Long-Term Evolution (LTE, 4G)				X		X	
Mobile WiMAX			a	X		X	

a. Can be used as a fallback

Circuit Emulation Services (CES)

There is a number of specifications defining circuit emulation services which could be used to support Mobile Backhaul services. During our event we tested implementations and observed demonstrations of MEF8 and RFC 4553 specification for E1 interfaces.

During the tests and demonstrations the devices were connected either back-to-back, back-to-back with an impairment generator of Calnex Paragon Sync emulating a network behavior between the two devices under test, or over the whole test network. We accepted a test or a demonstration if the two devices performing circuit emulation were able to pass E1 data over the packet based network and the deviation of the E1 signal received from the network compared to its input signal was within 50 parts per million (ppm) over 10 minutes.

As shown in the CES tests back-to-back figure in total 5 products from three different vendors passed the tests: Alcatel-Lucent 9500 MPR, NEC CX2600, NEC PASOLINK NEO TE, RAD IPMUX-216/24, and RAD MiTOP-E1/T1 hosted by the RAD ETX-202A. All tests were performed using MEF8 for encapsulation and adaptive clocking for clock synchronization. The test between Alcatel-Lucent 9500 MPR and RAD IPMUX-216/24 was performed once with and once without the optional RTP (Real Time Protocol) header. All other tests were performed without RTP. As described in RFC 4197 section 4.3.3, the usage of RTP relaxes the tolerance requirement for the internal clocks of the devices performing CES and therefore

decreases the probability of jitter buffer overflow or underflow.

In addition, CES was demonstrated over the whole test network as shown in the diagram ., and tested back-to-back with the Calnex Paragon Sync impairment tool, as shown in Figure 6: CES tests across the network. The Calnex Paragon Sync emulated the jitter of a network path with 10 nodes and 40% traffic utilization for a more realistic scenario.

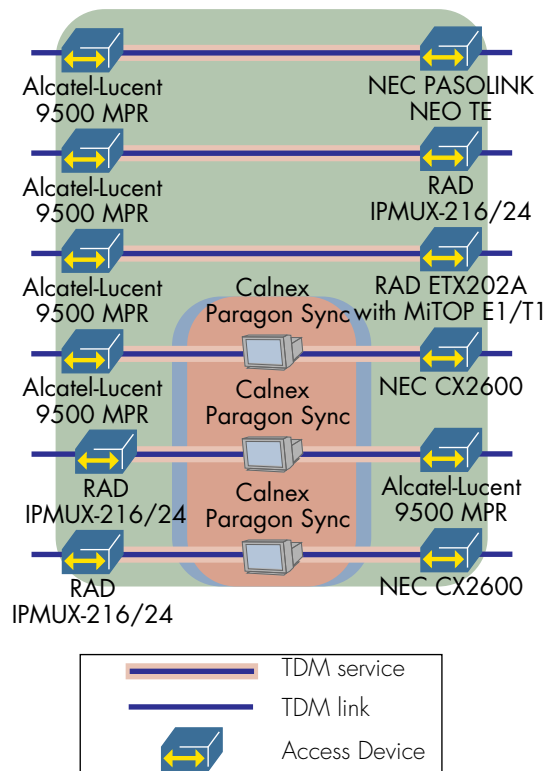

Figure 5: CES tests back-to-back

A number of microwave solutions participated in this event and have demonstrated their ability to transport E1 TDM data over their microwave links, namely Alcatel-Lucent 9500 MPR, Ceragon FibeAir IP-10, and NEC PASOLINK NEO. The Alcatel-Lucent 9500 MPR microwave solution performed at the same time circuit emulation service.

RAD Data Communications demonstrated IETF circuit emulation (SAToP, RFC 4553) over MPLS which is very similar to the MEF8 specification. In one case the Circuit Emulation Service was demonstrated between RAD ACE-3200 and RAD ACE-3205 in MPLS metro network. The Ceragon FibeAir IP-10 microwave solution was connected both between the RAD ACE-3200 and E1 source, and also between the RAD ACE-3200 and an MPLS metro edge device. Ceragon Networks and RAD Data Communications demonstrated a hybrid mobile backhaul network operation, effectively combining native TDM transport and Ethernet encapsulated CES. In another test case SAToP CES was demonstrated between RAD ACE-3400 and RAD ACE-3205 in PBB-TE network.

Alcatel-Lucent demonstrated MEF8 CES with differential clocking by using RTP (Real Time Protocol) header between Alcatel-Lucent 9500 MPR and Alcatel-Lucent 9500 MPR devices over T-MPLS metro network. In the same demonstration Alcatel-Lucent showed its proprietary solution to synchronize two microwave endpoints over the air by transporting the clock information from the Alcatel-Lucent 9500 MPR performing the CES to another Alcatel-Lucent 9500 MPR over the air.

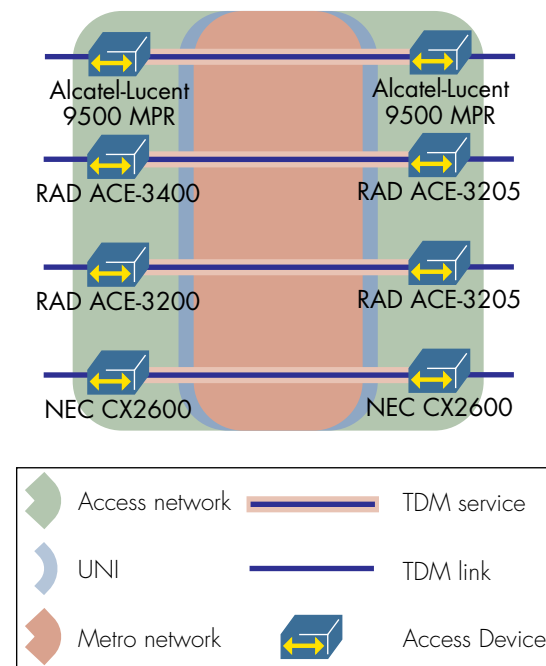

Figure 6: CES tests across the network

ATM Transport over MPLS

As described in the introduction, ATM transport services over a Packet Switched Network (PSN) is another key requirement for the migration of Mobile Backhaul to packet switched networks. During the event two implementations of ATM transport over MPLS as specified in RFC 4714 were tested and demonstrated.

Successful interoperability was tested between Nokia Siemens Networks Flexi WCDMA BTS and RAD ACE-3200. The two devices encapsulated ATM data into a statically configured MPLS pseudowire and sent the resulting MPLS packets over an IP tunnel across the PSN. The ATM pseudowire was used to transport an ATM circuit configured between Nokia Siemens Networks RACEL, a Radio Network Controller (RNC) and mobile core network emulator, and Nokia Siemens Networks Flexi WCDMA BTS.

In addition, RAD Data Communications demonstrated a statically configured ATM pseudowire between the RAD ACE-3205 and RAD ACE-3400 devices. This pseudowire was tunneled over the PBB-TE network.

Physical Network Topology

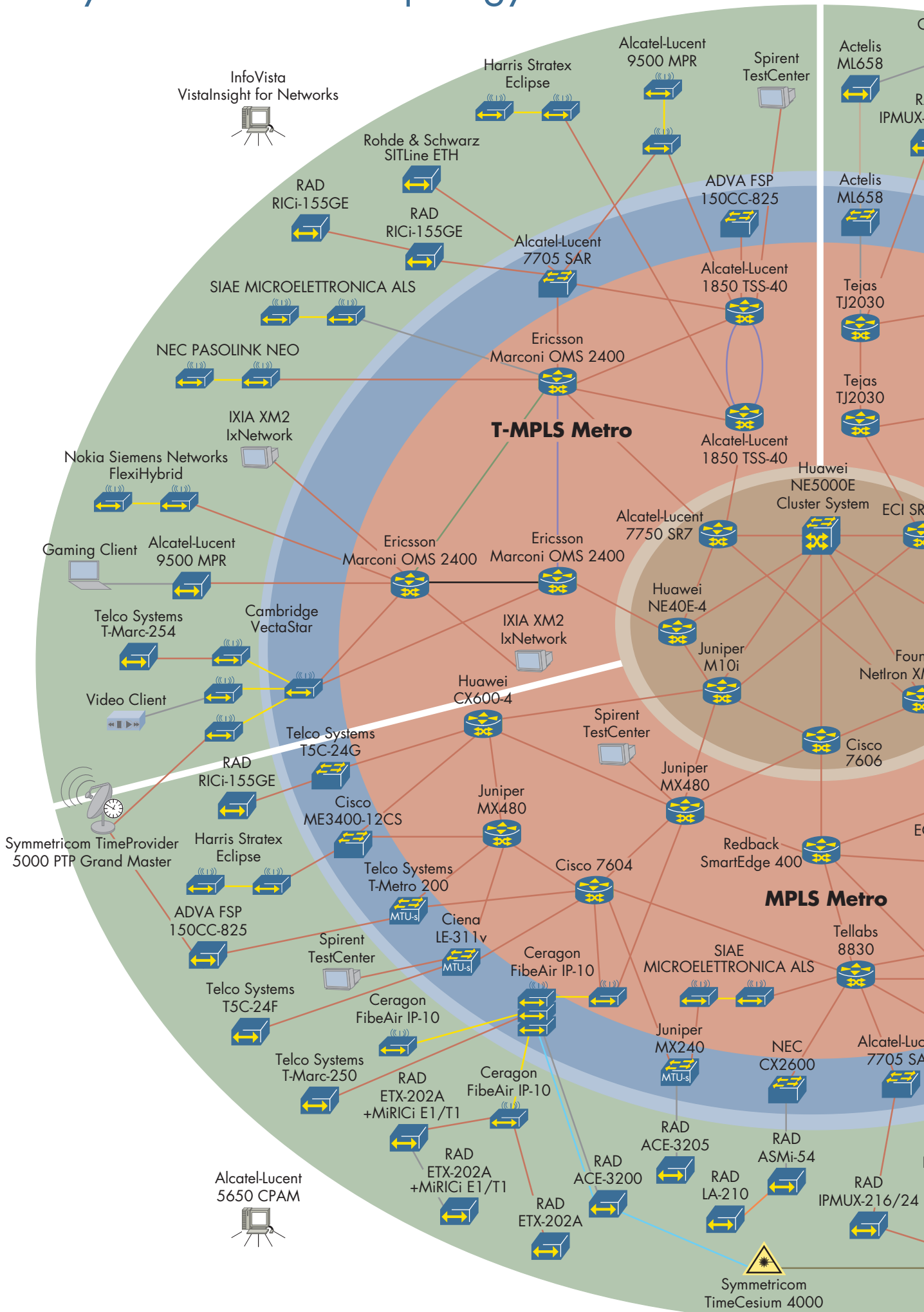

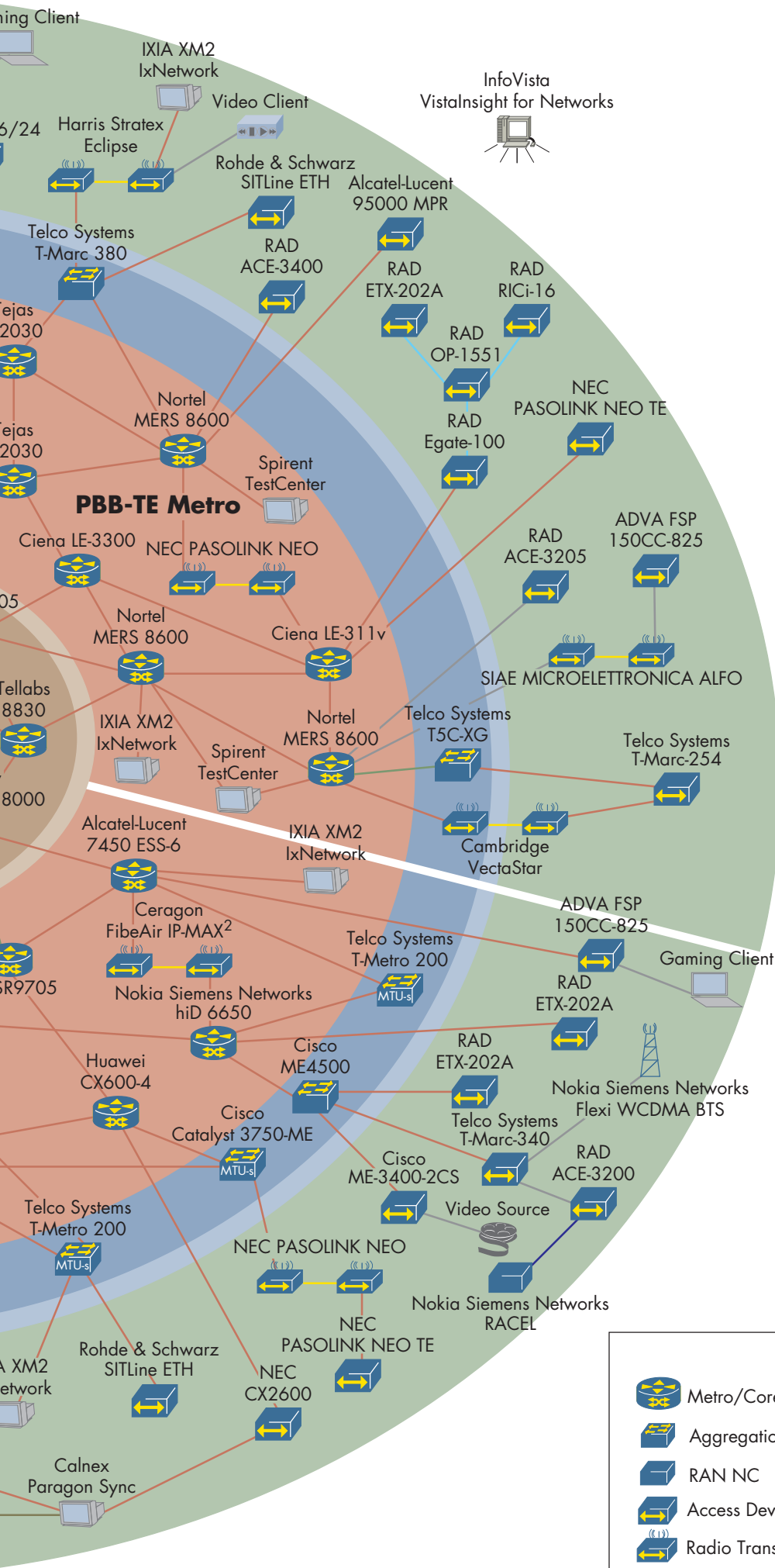

Application Demonstrations

- Gaming Clients } running on E-LAN
- Video Source } running on E-Tree
- Video Client }

Connection Types

- Gigabit Ethernet
- Fast Ethernet
- TDMoNx/E1/STM-1
- ATMoNx/E1/STM-1
- SHDSL
- G.SHDSL.bis
- Wireless
- 10 Gbit G709
- STM-16
- 10 Gbit Eth
- 10 MHz Clock

Network Areas

- Aggregation network
- Metro network
- Access network
- Core network
- UNI
- E-NNI

Device Types

- Metro/Core Network Device
- Aggregation Device
- RAN NC
- Access Device
- Radio Transmission Device
- RAN BS
- Tester
- P Router
- Cluster System

Clock Synchronization Introduction

Across all mobile network technologies, clock synchronization is a topic of interest and major concern today. Base stations within a mobile operator's domain require a common clock for three reasons:

- General operation and frequency stability. Base stations need to keep their transmit frequencies and time slots very stable to avoid interferences.
- Base station hand over. Voice calls shall not drop when the cell phone is moving from one cell's coverage area to the next. Clock frequencies of the two base stations need to be synchronous to ensure that the phone can continue sending within its pre-assigned mobile network slots nearly uninterruptedly.
- Common frequency transmission. In some mobile technologies, adjacent base stations transmit using identical frequencies, leading to a large common frequency coverage area and allowing the communication of end systems with multiple base stations at the same time (MIMO). This network service requires phase synchronization of base station clocks to ensure that their signals do not extinguish each other.

The easiest way of providing a common clock is to use GPS. However, mobile operators do not always prefer this solution due to technical or political reasons. Sometimes base stations do not have visibility of the sky (pico cells in buildings, tunnels) or the GPS receiver installation would be too cumbersome (femtocells at home).

Network Type	Frequency Synchronization	Phase Synchronization
GSM	X	
3G (UMTS, CDMA2000)	X	
4G (LTE including MBMS)	X	X
4G (Mobile WiMAX)	X	X

Vendors offer a number of network-based clock synchronization mechanisms. They can be selected depending on the precision requirements. For mobile backhaul, the base station frequency needs to be accurate to below 50 ppb (ITU-T G.812). The network clock needs to be three times more accurate to reach this goal — 16 ppb (ITU-T G.8261 draft).

Clock Synchronization Test Results

IEEE1588v2. For the first time in a public Mobile Backhaul test, we verified interoperability of IEEE 1588v2 based clock synchronization implementations at this event. Symmetricom provided a TimeProvider 5000 PTP Grand Master implementing the

Precision Time Protocol (PTP); Nokia Siemens Networks' Flexi WCDMA BTS received the PTP packets as a slave clock over an E-Line across the backhaul network. Calnex Solutions connected their Paragon Sync in between the master and slave clock, witnessing the protocol exchange and intentionally dropping packets.

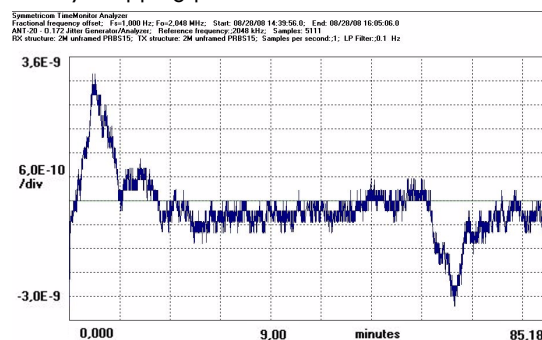

Figure 7: 1588v2 Synchronization measurement

The master and slave clocks interoperated successfully using the subset of IEEE 1588v2 Precision Time Protocol required for frequency synchronization — the unidirectional SYNC messages. Via an E1 output of the base station and using a Symmetricom software, we examined the frequency accuracy of the base station. Figure 7 shows the first 85 minutes of a clock deviation measurement of the Nokia Siemens Networks Flexi WCDMA BTS synchronized via IEEE 1588v2 to the Symmetricom TimeProvider 5000 PTP Grand Master clock. We started the measurement after the first five minutes of device operation — the amount of time the devices require for the initial clock synchronization. As shown in the diagram there is a peak of frequency deviation in the first two minutes of the measurement, and another peak at around 20–30 minutes. In any case, the deviation never exceeded 3.6 ppb (parts-per-billion). The deviation was most often measured at around 0.6 ppb. The measured results demonstrates the accurate synchronization of the Flexi WCDMA BTS, and the test goal to achieve a frequency deviation of below 16 ppb was fulfilled. Although we did not conduct long term measurements as required in ITU standards due to a lack of time at the hot staging; the same test will be conducted live at CEWC for visitors to witness the clock accuracy maintained throughout the conference.

For the same reasons, PTP impairments generated by the Calnex Paragon Sync did not show visible effects. The base station has an internal temperature-controlled quartz as a fallback clock when the incoming IEEE 1588v2 signal is lost. This clock is accurate enough for a couple of days of operation; we lacked the time to wait for it to degrade.

Adaptive Clocking. Another solution for some frequency synchronization scenarios is adaptive clocking. In this solution, the clock is regenerated from the frequency of bits arriving on an emulated TDM circuit. Assuming that the transmitter sends packets at a known rate and precise intervals, the

adaptive mode is usually accomplished on slaves by either measuring packets inter-arrival time or monitoring a buffer fill level (some adaptive clock recovery mechanisms may also use timestamps). Adaptive clock works only for constant bit rate services.

As described in the "Circuit Emulation Service" chapter, the Alcatel-Lucent 9500 MPR, NEC CX2600, NEC PASOLINK NEO TE, RAD IPMUX-216/24, and RAD MiTOP-E1/T1 hosted by the ETX-202A have successfully demonstrated and tested adaptive clocking.

In addition we measured the value of the frequency deviation as demonstrated between the RAD ACE-3200 and RAD ACE-3205 over a long measurement time. We connected the Symmetricom TimeCesium 4000 Master Clock to the RAD ACE-3200, and verified that the frequency accuracy was better than 16 ppb.

ETHERNET OAM

EANTC interoperability events have integrated Ethernet Operations, Administration and Management (OAM) testing since 2006. Several different protocols fall under the category of *Ethernet OAM*. In this event we have tested Ethernet in the

First Mile (EFM), and Connectivity Fault Management (CFM), standardized by the IEEE under 802.3ah and 802.1ag respectively, Y.1731, standardized by ITU-T, and E-LMI, specified by MEF. Over the past years we have seen a significant increase in support in this area – in the first event four vendors tested their CFM implementations and five vendors tested their EFM code. At our current event 12 vendors tested their EFM and CFM implementations.

Our service provider panel placed a high value on both Ethernet OAM test areas and with the inclusion of both EFM and CFM in the new MEF 20 "User Network Interface (UNI) Type 2 Implementation Agreement" technical specifications a clear continuous need for testing has been established

Link OAM

Link OAM is the name used by the Metro Ethernet Forum (MEF) to refer to clause 57 of the IEEE 802.3 standards where OAM is defined for Ethernet in the First Mile. The protocol monitors the health and operations of the UNI's physical layer. The MEF requires the usage of Link OAM between the UNI-N and UNIC starting from UNI type 2.2 and recom-

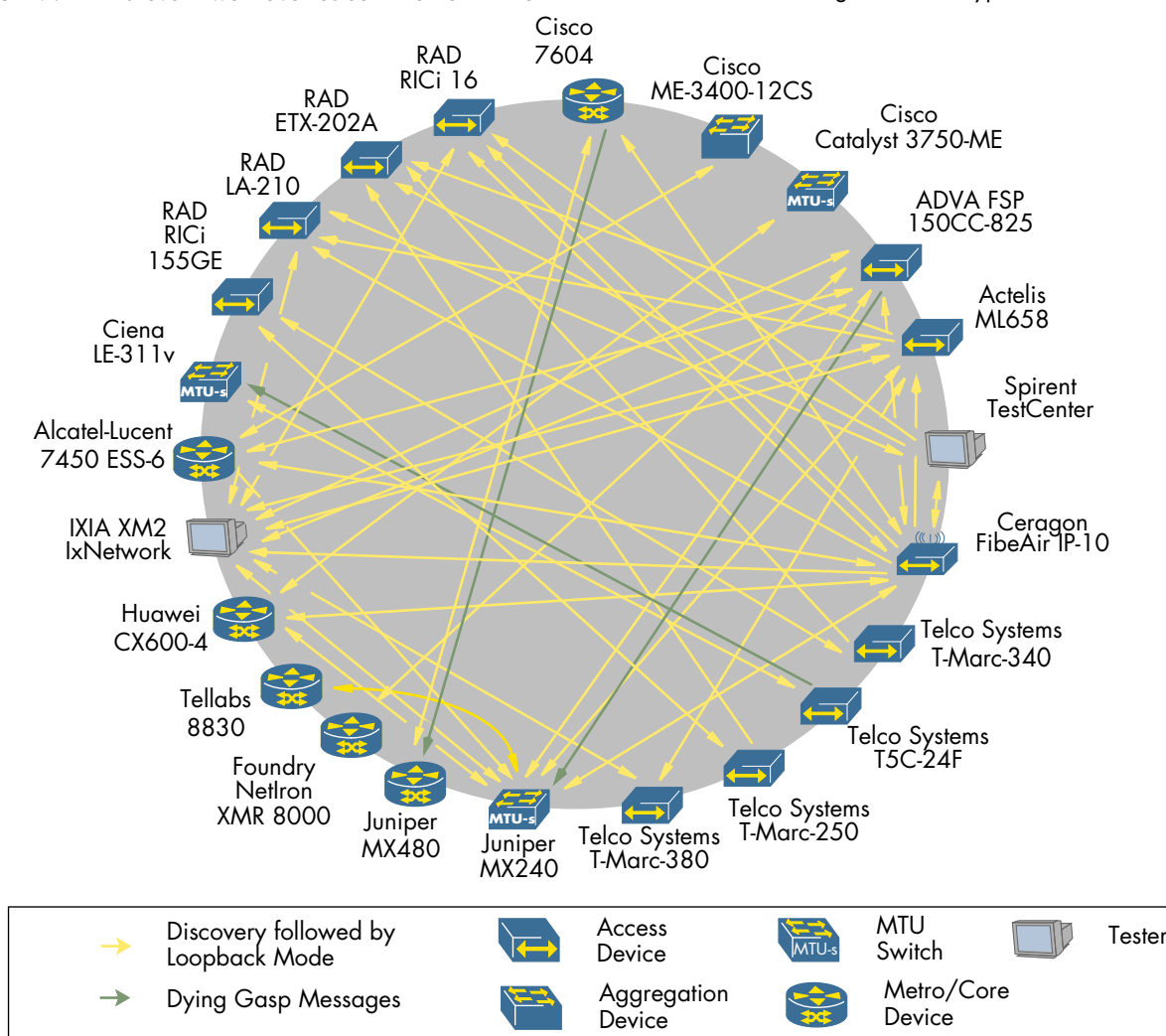

Figure 8: Ethernet Link OAM test results

mends the use of the protocol starting from UNI type 2.1.

The idea behind the protocol is to assist operators in localizing last mile physical layer errors. The most logical location in the network where the protocol could be used is between the Provider Edge device (a router or a switch) and the customer premises device. Both devices can identify themselves to each other and communicate problems with each other. The Provider Edge device can use a palette of tools to verify that it can reach the customer premises device therefore saving the provider the extreme cost of sending engineers to the customer site to verify physical link issues.

The following products successfully participated in the Link OAM tests discovering and setting each other in loopback mode: Actelis ML658, ADVA FSP 150CC-825, Alcatel-Lucent 7450 ESS-6, Ceragon FibeAir IP-10, Cisco 7604, Cisco Catalyst 3750-ME and Cisco ME-3400-2CS, Ciena LE-311v, Foundry NetIron XMR 8000, Huawei CX600-4, Ixia XM2 IxNetwork, Juniper MX240, RAD RICi155GE, RAD ETX-202A, RAD LA-210 and RAD RICi-16, Spirent TestCenter, Telco Systems T-Marc-250, Telco Systems T-Marc-380, Telco Systems T-Marc-340, Telco Systems T5C-24F, and Tellabs 8830.

We performed an additional test within this area verifying that a device, usually on the customer premises is able to notify the Provider Edge device

that the loss of signal is due to the customer premise device being shut down. The message carried in the Link OAM frame is aptly called Dying Gasp. Three vendor pairs successfully performed this test: ADVA FSP 150CC-825 and Juniper MX240, Cisco 7604 and Juniper MX480 and Ciena LE-311v with Telco Systems T5C-24F.

Service OAM

The IEEE 802.1ag standard defines end-to-end Ethernet based OAM mechanisms which are referred to by the MEF as Service OAM. The support for Service OAM is mandatory starting from UNI type 2.1. In contrast to link OAM the major use of CFM for service providers and enterprises is to verify connectivity across different management domains. A carrier can define a management domain level to be used internally while allowing their customers to verify end-to-end connectivity over the network using a different CFM level.

Since the 802.1ag standard has been published in December 2007 this has been the first interoperability event where we could specify a finished version of the standards for testing which simplified the testing. From 12 vendors who participated in the testing, 11 had standards based implementations.

For this interoperability event we added a test at the request of the participating vendors to the Service

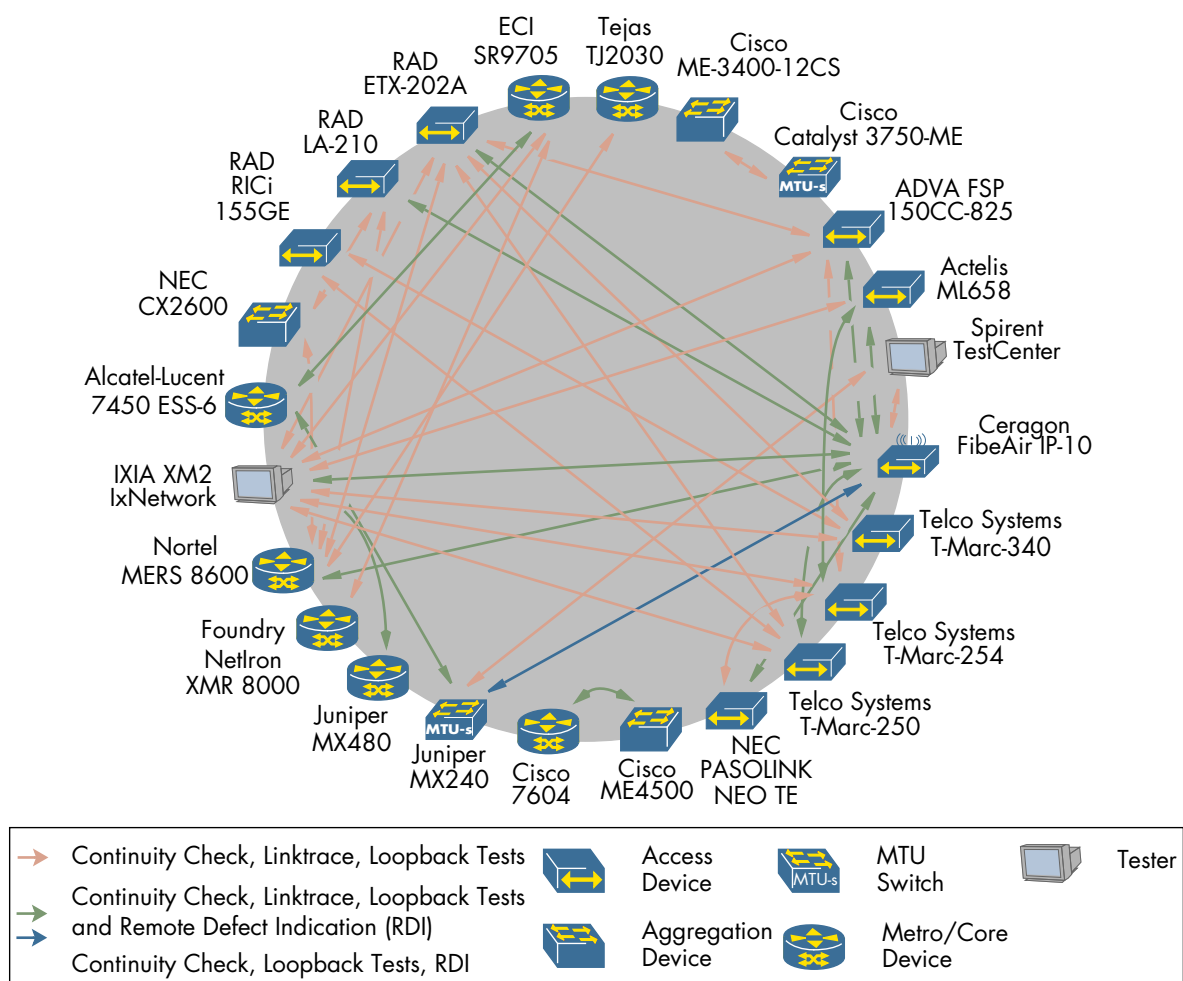

Figure 9: Service OAM Test Results

OAM area: Ethernet Remote Defect Indication (ETH-RDI). This message type, integrated into the Continuity Check Messages (CCMs), communicates to a remote Maintenance End Point (MEP) that a defect condition has been encountered. When a defect condition is encountered on a MEP, that MEP will set the RDI bit in CCMs for all Maintenance Entity Group (MEG) levels affected. When the defect condition is repaired or removed, the MEP will reset the RDI bit in the appropriate CCMs. This message type is particularly useful as a way to notify a remote MEP about MAC layer problems, changes to the configurations and such error conditions as sudden unidirectional connectivity.

The following vendors successfully tested Service OAM's Continuity Check, Linktrace and Loopback features as well as Remote Defect Indication: Actelis ML658, ADVA FSP 150CC-825, Alcatel-Lucent 7450 ESS-6, Ceragon FibeAir IP-10, ECI SR9705, Foundry NetTron XMR 8000, Ixia XM2 IxNetwork, Juniper MX240 and Juniper XM480, NEC CX2600 and PASOLINK NEO TE, Nortel MERS 8600, RAD RICi155GE, RAD ETX-202A, RAD LA-210, RAD RICi-16, Spirent TestCenter, Telco Systems T-Marc-254, Telco Systems T-Marc-250, Telco Systems T-Marc-340, and Tellabs 8830.

Cisco Systems demonstrated its pre-standard CFM implementation between its Catalyst 3400-12CS, 7604, ME4500, Catalyst 3750-ME, and the ME-3400-2CS. All devices were able to use CFM to discover each other, exchange Continuity Check Messages, recognize and signal failure conditions using Remote Defect Indicator (RDI) and Alarm Indication Signal (AIS) when failure were simulated in the demonstration topology and use loopback and linktrace messages.

Performance Monitoring

The ITU-T specification Y.1731 defines two message types for calculating loss and delay between two Ethernet OAM endpoints. Loss Measurement Messages (LMMs) are sent which should be replied to on arrival with Loss Measurement Replies (LMRs). The initiating device can make a calculation of average loss by comparing the number of frames sent by the initiating end with those received at the far end. Delay is measured in a similar way, calculating the time it takes for a Delay Measurement Reply (DMR) to come back for each Delay Measurement Message (DMM). Similar to CFM, this tool helps both customers to learn about the service they are receiving, and operators to learn about the service they are providing.

These tests were performed using the Paragon Sync impairment device provided by Calnex Solutions. First, messages were exchanged without any impairment to show a baseline interoperability. Then, loss and delay impairments were made to test the accuracy of the calculations.

The following devices tested their implementations of the two protocols: Ciena LE-3300, NEC CX2600, Nortel MERS 8600, RAD ETX-202A, and RAD

LA-210. In all cases LMMs and DMMs were replied to with LMRs and DMRs. Despite this, many devices did not properly calculate frame loss. Delay calculations on the other hand showed a high degree of accuracy between the different devices.

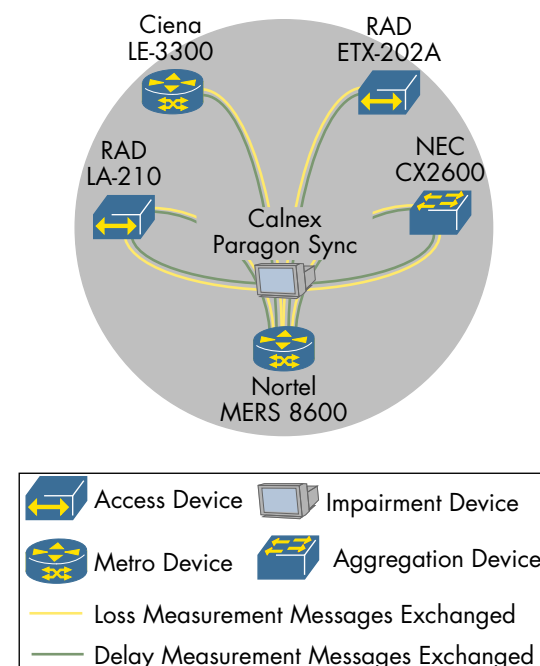

Figure 10: Performance Monitoring tests

While Performance Monitoring as specified in ITU-T standard Y.1731 has made its way into the test plan for previous EANTC interoperability events, this year marked the first set of results. This is underlined by the amount of issues found in the implementations under test.

E-LMI

The current UNI Type 2 Implementation Agreement (MEF 20) states in section 9 that all UNI-C and UNI-N of type 2.2 must support Ethernet Link Management Interface (E-LMI). MEF 16 technical specification defines procedures and protocols used for enabling automatic configuration of the customer equipment to support Metro Ethernet services in addition to relaying UNI and EVC status information to the customer equipment.

In the test case designed to test interoperability between E-LMI implementations we incorporated an additional step in which metro devices will propagate remote status indication over the EVCs and will use E-LMI to relay the information to the CE device. We were able to test the first half of the test case between Alcatel-Lucent 7450 ESS-6 and Cisco 7604 showing that the Alcatel-Lucent router was able to notify the Cisco router using LDP TLVs about its Access Circuit (AC) being down. Due to lack of time we did not verify the propagation of the message to the CE device using E-LMI.

RESILIENCE AND FAULT DETECTION

One of the key aspects of carrier grade transport technologies is SONET/SDH-like resiliency mechanisms and fault detection. Based on historical precedence, SONET/SDH's 50 ms restoration capabilities has been used as the measurement stick for all transport technologies to follow and these days, with Voice over IP (VoIP) and Mobile Backhaul we see a real need for 50 ms restoration time.

The sections to follow depict several failover and restoration tests that were performed during the event. We tested each transport technology's resilience protocols interoperability and augmented these by native fault detection mechanisms (CFM for PBB-TE and T-MPLS and Bidirectional Fault Detection (BFD) for MPLS). We focused our Link Aggregation tests on the UNI therefore providing a complete end-to-end resilience and fault detection story.

Link Aggregation

Several physical Ethernet ports of Ethernet switches can be bundled into a single logical Ethernet interface. This capability is used to increase the amount of bandwidth and/or to provide a link protection mechanism. The capability is specified in IEEE 802.3 clause 43, and commonly known as 802.3ad or just LAG (Link Aggregation Group). In order to create or change the members of a LAG group dynamically, Link Aggregation Control Protocol (LACP) has been standardized and is used between two Ethernet devices providing LAG.

The MEF specified LAG as a protection mechanism on the UNI. Devices supporting MEF UNI type 2.2 must support LAG and LACP which led us to require, as opposed to previous years, that vendors participating in this test will use LACP and not the static configuration of link aggregation groups.

In our lab we successfully tested LAG implementations of 10 vendors in total, two of them were analyzer vendors. As the test was defined for devices that implement UNI functionality we separated the participants into UNI-C and UNI-N devices. At the UNI-C were ADVA FSP 150CC-825, Ceragon FibeAir IP-10, Ixia XM2 IxNetwork and Spirent TestCenter, while on the UNI-N Alcatel-Lucent 7450 ESS-6, Ciena LE-3300, ECI SR9705, Nokia Siemens Networks hiD 6650, Redback SmartEdge 400, Telco Systems T5C-24G, and Telco Systems T-Metro-200. We first verified that the link aggregation groups were established between the two devices and then measured the failover time by pulling out of the primary link, followed by a measurement of the restoration time by reconnecting the primary link. In almost all cases we measured failover time below 31 ms, and restoration time below 25 ms. In one case we measured failover time of 550 ms and around two seconds restoration time.

Apart from the UNI, Link Aggregation can be used

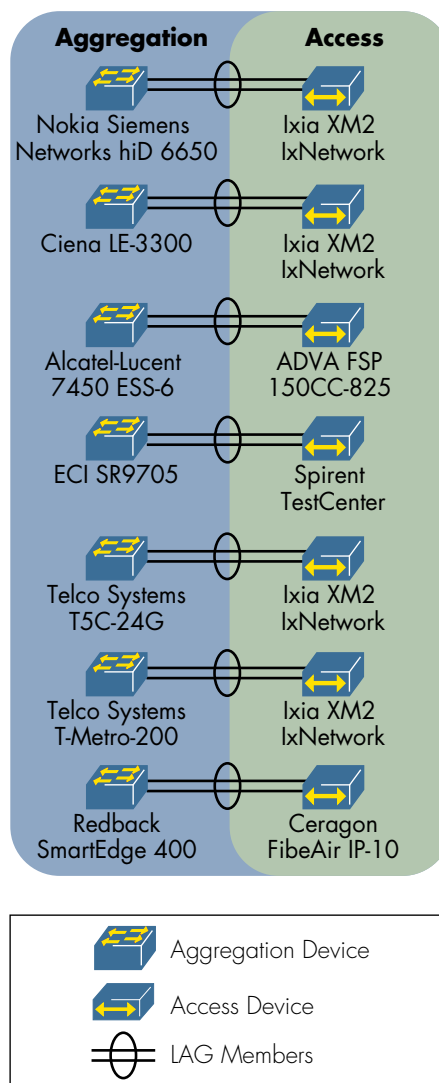

Figure 11: LACP test pairs

in the core of the network at the External Network to Network Interfaces (E-NNI) or to provided added link capacity. In addition to the LAG tests at the UNI, we performed some LAG tests between directly connected devices within the metro and core area networks. The test pairs included: Alcatel-Lucent 7750 SR7 and Ericsson Marconi OMS 2400, Cisco ME-3400-12CS and Juniper MX480, Nokia Siemens Networks hiD 6650 and Telco Systems T-Metro-200, and Spirent TestCenter with Foundry NetTron XMR 8000.

MPLS Protection

Several resilience mechanisms exist in MPLS and most have been tested in previous EANTC interoperability events. MPLS Fast Reroute (FRR) is one such mechanism that was tested in 2006 and 2007 (the white papers are available on EANTC's web site).

MPLS Fast Reroute provides link and node protection for Label Switched Paths (LSPs), therefore, protecting the services running within the LSPs. Since 12 vendors participated in the MPLS metro area, some of which for the first time, the event provided them with the opportunity to test their implementations against others that were not previously tested.

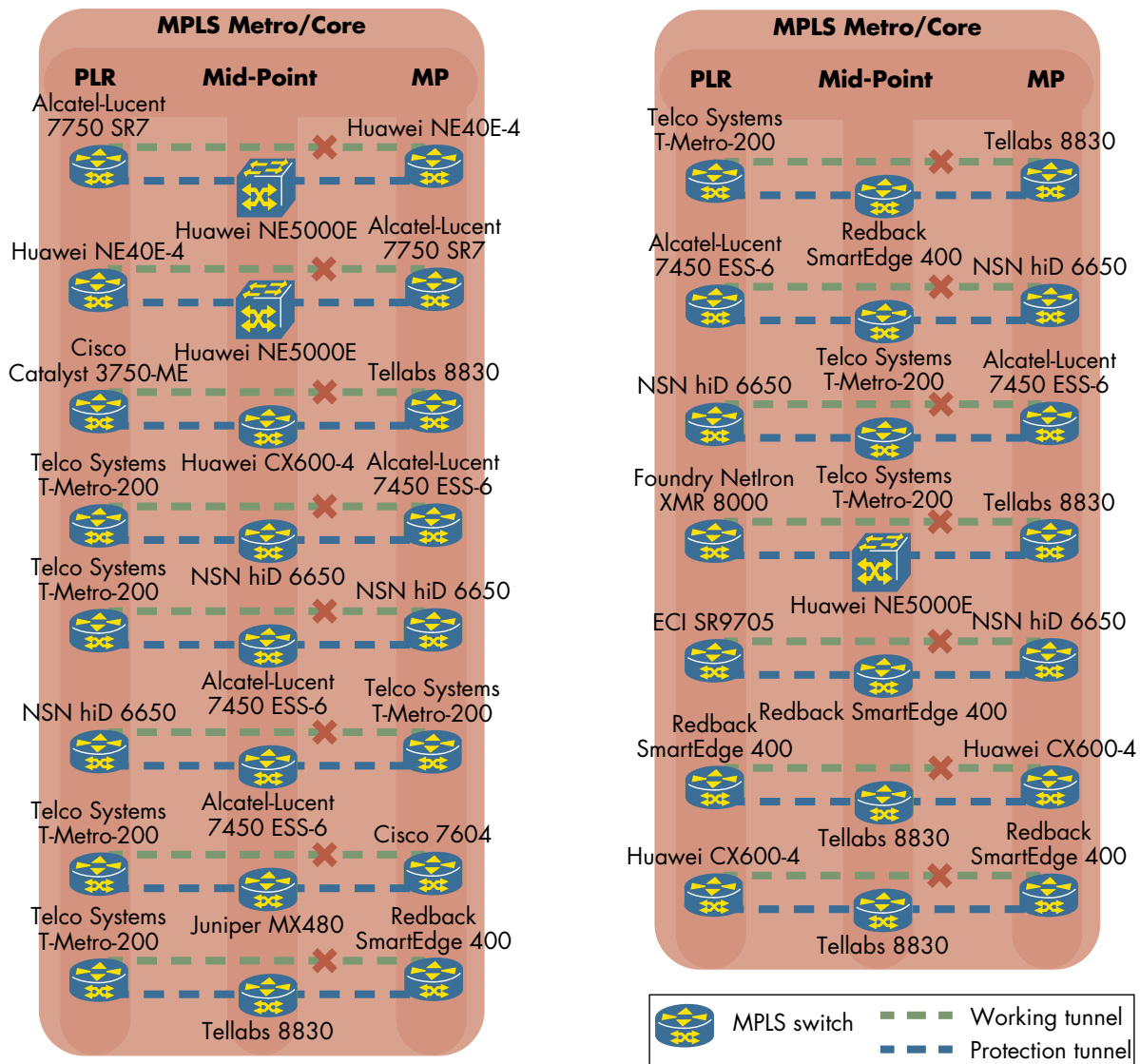

Figure 12: MPLS Fast Reroute test pairs

In total 14 different MPLS Fast Reroute tests were performed during the interoperability test event. In 12 of the combinations the MPLS Fast Reroute was triggered on the Point of Local Repair (PLR) by a Loss of Signal (LOS) which was simulated by pulling the active link from the PLR. The following devices participated in the role of the Point of Local Repair (PLR): Alcatel-Lucent 7450 ESS-6, Alcatel-Lucent 7750 SR7, Cisco Catalyst 3750-ME, ECI SR9705, Foundry Netron XMR 8000, Huawei CX600-4, Huawei NE40E-4, Nokia Siemens Networks hiD 6650, Redback SmartEdge 400, and Telco Systems T-Metro-200. The Merge Point (MP) is the router which merges the backup and primary segments of an MPLS tunnel. The following devices participated as MPs: Alcatel-Lucent 7450 ESS-6, Cisco 7604, Huawei CX600-4, Huawei NE40E-4, Nokia Siemens Networks hiD 6650, Redback SmartEdge 400, Telco Systems T-Metro-200, and Tellabs 8830. In 8 test combinations we measured failover times below 30 ms. In one test combination we measured failover time below 100 ms, and in 3 test combinations we measured failover times below 380 ms and above 100 ms. The importance of the test, however, was the protocol interoperability between the PLRs

and the MPs therefore we spent no time on trying to reconfigure the devices for faster failover times.

In two MPLS Fast Reroute test combinations the tunnel failure was recognized by Bidirectional Fault Detection protocol (BFD). BFD allows the routers to detect failures of non-directly attached links and signal the failure to its neighbors quicker than the IGP used in the network. In both tests the BFD transmission interval was configured to 50 ms.

In the test combination between Cisco 7604 (acting as PLR) and Juniper MX480 (acting as MP) the BFD failure detection was bound to the MPLS RSVP-TE tunnels configured for MPLS Fast Reroute. In this test out of service time of 154 ms was achieved.

In the test combination between Foundry Netron XMR 8000 and Tellabs 8830 the BFD failure detection was bound to the OSPF routing process. The failure triggered by BFD caused the rerouting in OSPF process. This result in rerouting of RSVP-TE messages and creation of a new segment of MPLS tunnel. We measured 207 ms out of service time for this test.

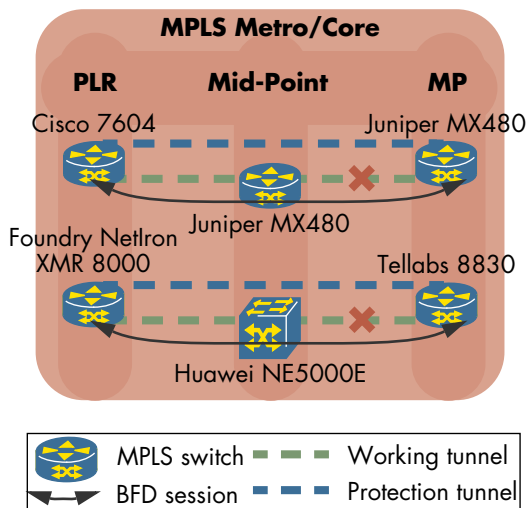

Figure 13: BFD test participants

Dual Homed MTU-s

In VPLS networks a hierarchical model can be installed by using Multi-Tenant Unit Switches (MTU-s) to offload the learning of MAC addresses and cut down drastically the MAC tables on the VPLS PEs. However, as these spoke MTU-s connections are not a complete part of the MPLS network, inherent MPLS resiliency mechanisms may not be available. Therefore, the VPLS RFC (4762) describes a dual homed model, which was successfully tested by the Ciena LE-311v versus the Cisco 7604 and Juniper MX480 PEs, and by the Telco Systems T-Metro-200 versus the ECI SR9705 and Nokia Siemens Networks hiD 6650 PEs.

PBB-TE Protection

Resiliency in the PBB-TE domain was accomplished by defining a protection PBB-TE trunk for a working trunk. In case of the single homed access devices the working and protection trunks had the same endpoints, but different mid-point PBB-TE switches. In case of the dual homing, a single access device was connected to two different PBB-TE switches, so that one endpoint of the working and protection trunks was different.

In both cases, the detection was done by trunk endpoint switches using CFM (CFM is described in the Service OAM section). In almost all cases the Continuity Check Messages (CCM) transmission interval was configured to 10 milliseconds (ms), and in one case to 3.3 ms.

The four vendors participating in the PBB-TE cloud were able to show PBB-TE protection interoperability, as shown in the figure 14. In most cases the failover time was below 51 ms, and restoration time below 5 ms. In one case the restoration time was 718 ms. The high restoration time was explained by differences between implementations. Some vendors shutdown traffic on a trunk when they revert over to the restored primary trunk and drop any traffic still running on the backup trunk. Other vendors continue

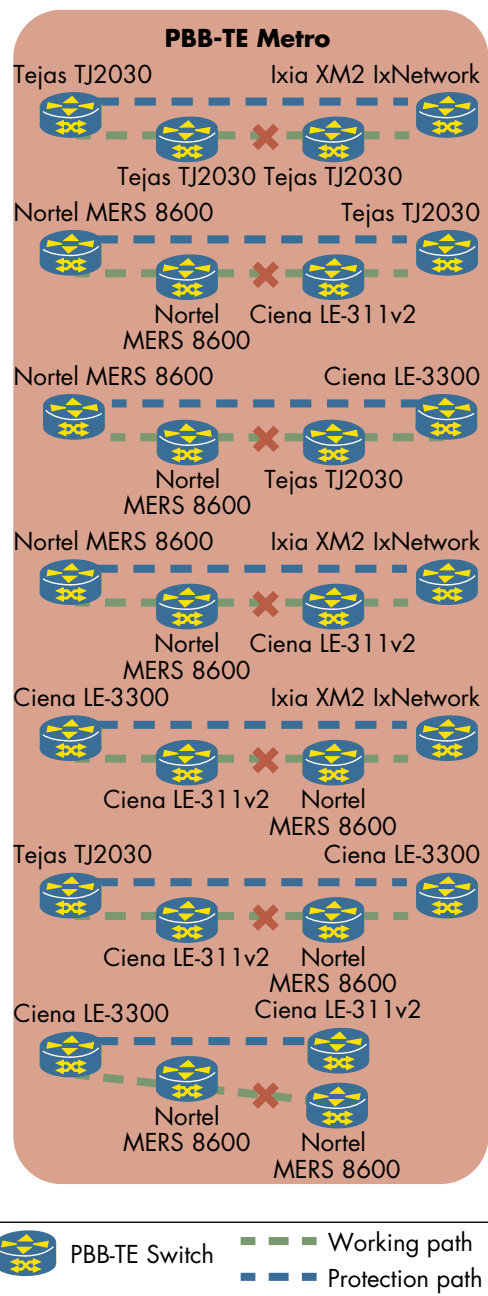

Figure 14: PBB-TE protection results

to receive traffic on both trunks, but only transmit on one trunk. This ensures that the traffic is still received and reaches the destination.

T-MPLS Protection

Multiple protection mechanisms exist in T-MPLS. Both T-MPLS path (T-MPLS path is equivalent to an MPLS tunnel) and T-MPLS channel (a T-MPLS channel is equivalent to an MPLS pseudowire) can be protected. During this event we demonstrated only the per path protection mechanisms.

The T-MPLS linear 1:1 and 1+1 path protection schemes were demonstrated by three Ericsson Marconi OMS 2400 devices for 10 Gigabit Ethernet, STM-16 and 10 Gigabit G.709 interfaces. The protection schemes required two paths to be build to the same destination. In the 1:1 protection

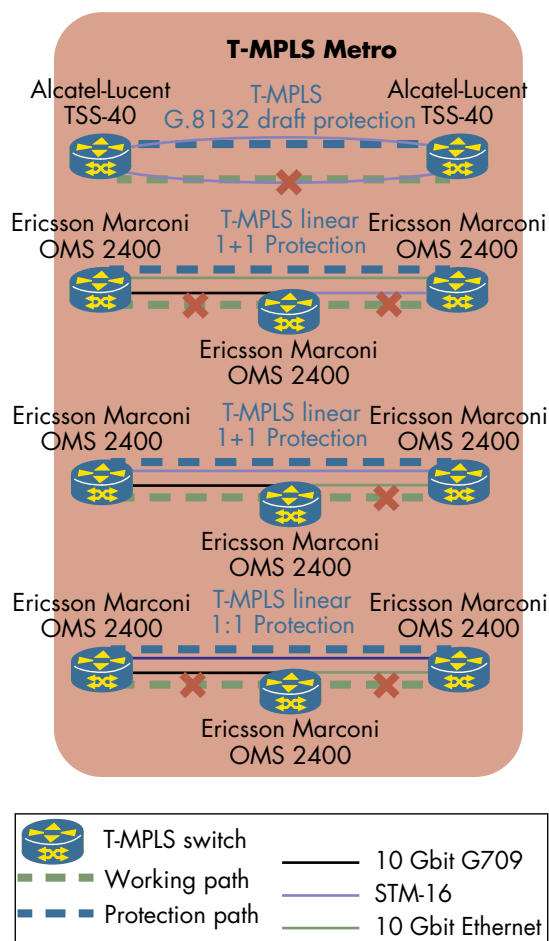

Figure 15: T-MPLS protection

one path is declared as active and the other is set in backup mode. When the active path fails traffic is switched to the backup path. The second scheme, 1+1 protection, replicate all frames across both active and backup paths such that when the primary path fails, the backup path is already carrying the lost frames. In almost all cases Ericsson demonstrated the failover and restoration times below 35 ms for 1+1 protection and failover times below 30 ms for 1:1 protection. The restoration time for 1:1 protection was under 0.5 ms. In one test run we measured 76 ms failover time over 10 Gigabit Ethernet link for 1+1 protection.

Alcatel-Lucent demonstrated with the TSS-40 devices a pre-standard G.8132 T-MPLS ring protection implementation over STM-16 interfaces. In its demonstration Alcatel-Lucent showed failover times below 30 ms and restoration time below 16 ms. The two vendors already showed T-MPLS protection interoperability during EANTC's Mobile Backhaul event in January 2008 (report available on EANTC's web site).

The T-MPLS demonstration results are summarized in the figure above.

MANAGEMENT AND SLA REPORTING

Since the inception of EANTC's interoperability events, we have been trying to interest management and Service Level Agreement (SLA) reporting vendors to join the event and to answer the challenge put forth by many service providers of measuring and reporting on multivendor network infrastructure. Especially these days when converged networks are meant to support any type of service, from residential Triple Play to sensitive Mobile Backhaul traffic, we see the need to monitor, measure and report on SLA performance in the network.

A customer will always be more impressed and likely to stay with a provider when, through proactive monitoring, problems are solved before they affect the end customer and SLAs are met.

InfoVista, using Vistalnsight for Networks, was able to demonstrate its multivendor SLA monitoring and reporting capabilities by measuring jitter, frame delay, frame delivery ratio, interface utilization statistics, and Ethernet OAM measurements on the ADVA FSP 150CC-825 for an EVC with another FSP 150CC-825, Alcatel-Lucent SAM, and Cisco ME-3400-12CS for an EVC with the Cisco Catalyst 3750-ME. In addition, Vistalnsight for networks identified and monitored SNMP Management Information Base (MIB) objects on the participating devices from Cisco Systems, ECI Telecom, Huawei Technologies, Foundry Networks, Juniper Networks, Nortel, and Tellabs.

Alcatel-Lucent demonstrated the 5650 Control Plane Assurance Manger (CPAM), a vendor agnostic IP/MPLS control plane management solution, which provided real-time IGP topology maps, control plane configuration, and a look into route advertisements within the layer 3 services. The tool was helpful since many configurations were being made by many different operators, helping to quickly identify configuration issues.

Editors

This document has been edited by Jambi Ganbar, Sergej Kaelberer, Jonathan Morin, Bionda Mueffke, Carsten Rossenhoevel and Gabriele Schrenk.

ACRONYMS

Term	Definition
AC	Access Circuit
AIS	Alarm Indication Signal
ATM	Asynchronous Transfer Mode
B-MAC	Backbone MAC
BFD	Bidirectional Fault Detection
BGP	Border Gateway Protocol
BRAS	Broadband Remote Access Server
BSC	Base Station Controller
CCM	Continuity Check Message
CDMA	Code Division Multiple Access
CE	Customer Edge
CE-VLAN	Customer Edge Virtual LAN
CES	Circuit Emulation Service
CFM	Connectivity Fault Management
CPE	Customer Premise Equipment
DMM	Delay Measurement Message
DMR	Delay Measurement Reply
DSL	Digital Subscriber Line
E-LAN	A multipoint-to-multipoint Ethernet service. A LAN extended over a wide area
E-Line	Point-to-Point Ethernet Service similar to a leased line ATM PVC or Frame Relay DLCI
E-LMI	Ethernet Link Management Interface
E-NNI	External Network-to-Network Interface
EFM	Ethernet in the First Mile
ERPS	Ethernet Ring Protection Switching
EVC	Ethernet Virtual Connection
EVPL	Ethernet Virtual Private Line
FRR	Fast ReRoute
GSM	Global System for Mobile
HSPA	High-Speed Packet Access
IGP	Internal Gateway Protocol
IS-IS	Intermediate System to Intermediate System
LACP	Link Aggregation Control Protocol
LAG	Link Aggregation Group
LDP	Label Distribution Protocol
LER	Label Edge Router
LMM	Loss Measurement Message
LOS	Loss Of Signal
LSP	Label Switched Path
LTE	Long-Term Evolution (4th generation 3GPP mobile services)
MAC	Media Access Control
MBMS	Multimedia Broadcast Multicast Services, integral part of LTE

Term	Definition
MBMS	Multimedia Broadcast Multicast Service
MEG	Maintenance Entity Group
MEP	Maintenance End Point
MIMO	Multiple-Input and Multiple-Output
MPLS	Multi-Protocol Label Switching
MPLS-TP	MPLS Transport Profile
MSC	Mobile Switching Center
MTU-s	Multi Tenant Unit Switch
OAM	Operations, Administration and Maintenance
OPEX	OPERating EXpenditure
OSPF	Open Shortest Path First
PBB	Provider Backbone Bridge
PBB-TE	Provider Backbone Bridge Traffic Engineering
PE	Provider Edge
PLR	Point of Local Repair
PLSB	Provider Link State Bridging
ppb	parts-per-billion
ppm	parts-per-million
PSN	Packet Switched Network
PTP	Precision Time Protocol
PW	PseudoWire
QAM	Quadrature Amplitude Modulation
QoS	Quality of Service
RDI	Remote Defect Indication
RFC	Request For Comments
RNC	Radio Network Controller
RSTP	Rapid Spanning Tree Protocol
RSVP-TE	Resource reSerVation Protocol Traffic Engineering
RTP	Real Time Protocol
S-Tag	Service Tag
SAToP	Structure-Agnostic Time Division Multiplexing (TDM) over Packet
SGSN	Serving GPRS Support Node
SLA	Service Level Agreement
T-MPLS	Transport MPLS
TMC	T-MPLS Channel
TMP	T-MPLS Path
UMTS	Universal Mobile Telecommunications System
UNI	User-Network Interface
VLAN	Virtual Local Area Network
VoIP	Voice over IP
VPLS	Virtual Private LAN Service
VPN	Virtual Private Network
VPWS	Virtual Private Wire Service

REFERENCES

- Ethernet Services Attributes Phase 2 (MEF 10.1)
- Requirements and Framework for Ethernet Service Protection in Metro Ethernet Networks (MEF 2)
- Circuit Emulation Service Definitions, Framework and Requirements in Metro Ethernet Networks (MEF 3)
- Metro Ethernet Network Architecture Framework - Part 1: Generic Framework (MEF 4)
- Ethernet Service Definitions (MEF 6)
- Implementation Agreement for the Emulation of PDH Circuits over Metro Ethernet Networks (MEF 8)
- Abstract test suite for Ethernet Services at the UNI (MEF 9)
- User Network Interface (UNI) Requirements and Framework (MEF 11)
- User Network Interface (UNI) Type 1 Implementation Agreement (MEF 13)
- Abstract Test Suite for Traffic Management Phase 1 (MEF 14)
- Ethernet Local Management Interface (E-LMI) (MEF 16)
- User Network Interface (UNI) Type 2 Implementation Agreement (MEF Ballot)
- Provider Bridges (IEEE 802.1ad-2005)
- Provider Backbone Bridges (IEEE 802.1ah, draft 4.2)
- Provider Backbone Bridges Traffic Engineering (IEEE 802.1qay, draft 3)
- Shortest Path Bridging (IEEE 802.1aq)
- Media Access Control (MAC) Bridges (IEEE 802.1D)
- Media Access Control (MAC) Bridges Amendment 2:Rapid Reconfiguration (IEEE 802.1W)
- Virtual Bridged Local Area Networks (IEEE 802.1Q)
- Link Aggregation Control Protocol (IEEE 802.3ad)
- Carrier Sense Multiple Access with Collision Detection (CSMA/CD) Access Method and Physical Layer Specifications. Amendment: Media Access Control Parameters, Physical Layers, and Management (IEEE Std 802.3ah-2004)
- Virtual Bridged Local Area Networks - Amendment 5: Connectivity Fault Management (IEEE 802.1ag-2007)
- Pseudowire Setup and Maintenance Using the Label Distribution Protocol (LDP) (RFC 4447)
- Virtual Private LAN Service (VPLS) Using BGP for Auto-Discovery and Signaling (RFC 4761)
- Virtual Private LAN Service (VPLS) Using Label Distribution Protocol (LDP) Signaling (RFC 4762)
- Fast Reroute Extensions to RSVP-TE for LSP Tunnels (RFC 4090)
- BGP/MPLS IP Virtual Private Networks (VPNs) (RFC 4364)
- Architecture of Transport MPLS (T-MPLS) Layer Network (ITU-T G.8110.1)
- Interfaces for the Transport MPLS (T-MPLS) Hierarchy (ITU-T G.8112)
- Characteristics of Multi Protocol Label Switched (MPLS) Equipment Functional Blocks (ITU-T G.8121)
- Encapsulation Methods for Transport of Asynchronous Transfer Mode (ATM) over MPLS Networks (RFC 4717)
- Structure-Agnostic Time Division Multiplexing (TDM) over Packet (SAToP) (RFC 4553)
- BFD For MPLS LSPs (draft-ietf-bfd-mpls-06.txt)
- Bidirectional Forwarding Detection (draft-ietf-bfd-base-08.txt)
- Generic Application of BFD (draft-ietf-bfd-generic-04.txt)
- BFD for IPv4 and IPv6 (Single Hop) (draft-ietf-bfd-v4v6-1hop-08.txt)
- Circuit Emulation Services Interoperability Specification, Version 2.0 (ATM Forum af-vtoa-0078.000, January 1997, <ftp://ftp.atmforum.com/pub/approved-specs/af-vtoa-0078.000.pdf>)
- Framework for MPLS in Mobile Backhaul Networks (IP/MPLS Forum 2007.102.03)
- Timing and synchronization aspects in packet networks (ITU-T G.8261/Y.1361)
- OAM Functions and Mechanisms for Ethernet Based Networks (ITU-T Y.1731)



EANTC AG
European Advanced Networking Test Center

Einsteinufer 17
10587 Berlin, Germany
Tel: +49 30 3180595-0
Fax: +49 30 3180595-10
info@eantc.de
www.eantc.com



IIR Telecoms

29 Bressenden Place
London SW1E 5DR, UK
Tel: +44 20 7017 7483
Fax: +44 20 7017 7825
registration@iir-conferences.com
www.carrierethernetworld.com

This report is copyright © 2008 EANTC AG. While every reasonable effort has been made to ensure accuracy and completeness of this publication, the authors assume no responsibility for the use of any information contained herein.

All brand names and logos mentioned here are registered trademarks of their respective companies in the United States and other countries.

v1.1